



TECHNIUM
SOCIAL SCIENCES JOURNAL

Vol. 33, 2022

**A new decade
for social changes**

www.techniumscience.com

ISSN 2668-7798



9 772668 779000

Accelerating integration of immigrants using artificial intelligence-driven solutions: The panacea for integration gaps in Finland

Frank Ojwang

Faculty of Social Sciences, University of Lapland

fojwang@ulapland.fi

Abstract. Artificial Intelligence (AI) is revolutionizing micro and macro-aided decision-making processes across various sectors and disciplines worldwide. This paper uses the probability technique to theoretically forecast AI-aided integration program potential to offer accelerated, concrete and individualized integration support for new and ‘old’ resident immigrants throughout their stay in Finland. The algorithms are based on various taxonomies and topologies for individualized self-paced, life-long situation-specific integration support. This action research article theoretically reviews two high-quality peer-reviewed publications on AI in aging through systematic reviews and meta-analyses, combining results from multiple impact evaluation studies to construct arguments and draw conclusions for the use of AI in accelerating new migrants’ integration in Finland. Data is analyzed qualitatively and quantitatively to deduce realistic predictions. This article uses grounded theory to test theories that underscore the role and impact of AI in accelerating integration. This article presents the foundation on which future integration programs will be implemented.

Keywords. Artificial Intelligence, Applied research, Integration, Probabilities

1.0 Introduction

Migration is among the top five megatrends in the world in 2021-2022 as cited by PriceWaterhouseCoopers (PWC, 2022) and Project Management Institute (PMI, 2022). The migration conundrum remains a complex puzzle that requires tactful approaches in order to streamline the migration process and the post-migration activities including integration. Migration researchers and policy makers continuously seek efficient and cost-effective approaches to handle migration and post-migration issues in a sustainable manner. One of the critical aspects in the post-migration phase is the integration of an immigrant into the society. Immigrants face countless challenges to integrate into their new host countries. Immigrants from the global south particularly face numerous challenges to integrate into the global north. The Nordic countries have developed integration programs to aid in the handling and management of post-migration challenges faced by immigrants. Finland offers integration support in the first three years of an immigrant’s arrival in Finland. The primary objective of the integration program in Finland is to help the new immigrants to settle well and be able to

access the labour market and learn the Finnish or Swedish languages, the official languages used in Finland.

A holistic approach to solving migration issues that is spearheaded by a tactfully designed integration program, provides a potential sustainable, accelerated solution for immigrants today and in the future. The range of post-migration challenges in the high North including in Finland are difficulty in joining the labour market and non-recognition of global South qualifications, language capacity challenges, forecasted ageing issues among immigrants and other reasons (Ndomo & Lillie, 2020). A sample of immigrants that had completed the integration program in Finland were interviewed and they felt that the integration program was not impactful as they continued to face similar challenges. A proposed predictive model driven by algorithmic intervention plan for immigrants in Finland has the potential to accelerate and improve integration process leading to visible impact. Immigrants are reported to face socially constructed realities sooner rather than later. Migration to the high North has the potential to increase longevity for African immigrants considering the quality of life in the high North. It is desirable that the long life of immigrants from the global South to Finland should be fulfilling, meaningful and gratifying.

According to Finnish Immigration Service (2020), most immigrants come to Finland to work. Work remained the leading basis for migration despite the coronavirus pandemic that broke out in early 2020. The researcher believes that African youth and working-age adults dream and aspire to migrate to the global North in pursuit of a better life and promising future. The researcher further notes that the social constructs vs realities hit the immigrants hardest, making their lives as immigrants challenging and void of sentimental fulfilment. The researcher believes that Artificial Intelligence presents a formidable accelerated solution-provider to human challenges in several spheres of life including migration. Several integration challenges identified by scholars have the potential to be solved satisfactorily using AI-driven interventions. In the taxonomies of work, family, education, refugee/ asylum seekers and aging, AI algorithms expands the taxonomies using various topologies that accelerate integration process.

2.0 Literature Review

Nearly all aspects of modern life are in some way being changed by big data and machine learning. Netflix knows what movies people like to watch and Google knows what people want to know based on their search histories. Indeed, Google has recently begun to replace much of its existing non-machine learning technology with machine learning algorithms, and there is great optimism that these techniques can provide similar improvements across many sectors (beam & Kohane, 2018).

Artificial intelligence (AI) is a wide-ranging tool that enables people to rethink how we integrate information, analyze data, and use the resulting insights to improve decision making—and already it is transforming every walk of life (West & Allen, 2018). AI is keen to offer recommendations for getting the most out of AI while still protecting important human values. The authors add that despite AI widespread lack of familiarity, it is a technology that is transforming every walk of life. They highlight that AI is a wide-ranging tool that enables people to rethink how we integrate information, analyze data, and use the resulting insights to improve decision-making. The authors outline steps for maximizing AI benefits that include an appeal for access to research data without compromising users' personal privacy; more government research in unclassified AI research; new models of digital education and AI workforce development; create federal AI advisory committee; engagement with local and state

actors for AI policy development and enactment; regulate broad AI principles rather than algorithms; take bias complaints serious so that AI does not replicate historic injustice; maintain mechanism for human oversight and control; and penalize malicious AI behavior and promote cybersecurity.

There exist vast and valuable bodies of research in philosophy, psychology, and cognitive science of how people define, generate, select, evaluate, and present explanations, which argues that people employ certain cognitive biases and social expectations to the explanation process (Miller, 2019). According to Miller, there has been a recent [resurgence](#) in the area of explainable artificial intelligence as researchers and practitioners seek to provide more transparency to their algorithms.

Some researchers introduce DeepProbLog, a neural probabilistic [logic programming](#) language that incorporates deep learning by means of neural predicates (Manhaeve; Dumančić; Kimmig; Demeester; & Raedt, 2021). The authors show how existing inference and learning techniques of the underlying probabilistic logic programming language ProbLog can be adapted for the new machine learning language. Their article theoretically and experimentally demonstrate that DeepProbLog supports (i) both symbolic and subsymbolic representations and inference, (ii) program induction, (iii) probabilistic (logic) programming, and (iv) (deep) learning from examples. This work is the first to propose a framework where general-purpose neural networks and expressive probabilistic-logical modeling and reasoning are integrated in a way that exploits the full expressiveness and strengths of both worlds and can be trained end-to-end based on examples.

A review of relevant evidence shows that AI may act as an enabler on 134 targets (79%) across all SDGs, generally through a technological improvement, which may allow to overcome certain present limitations. However, 59 targets (35%, also across all SDGs) may experience a negative impact from the development of AI. A study that divided the SDGs into three categories, according to the three pillars of sustainable development, namely Society, Economy, and Environment concluded that AI-powered technology has the potential to create and go mainly to those already well-off (countries) and educated, while job displacement leaves others worse off. Globally, the growing economic importance of AI may result in increased inequalities due to the unevenly distributed educational and computing resources throughout the world. Furthermore, the existing biases in the data used to train AI algorithms may result in the exacerbation of those biases, eventually leading to increased discrimination (Vinuesa, ym., 2020).

Identifying informative predictors in a high dimensional regression model is a critical step for association analysis and predictive modeling. Signal detection in the high dimensional setting often fails due to the limited sample size. One approach to improving power is through meta-analyzing multiple studies which address the same scientific question. However, integrative analysis of high dimensional data from multiple studies is challenging in the presence of between-study heterogeneity (Liu; Xia; Cho; & Cai, 2021). Theoretical comparisons of this testing procedure with the ideal individual-level meta-analysis (ILMA) approach and other distributed inference methods have the potential to improve simulation studies and demonstrate that the proposed testing procedure performs well in both controlling false discovery and attaining power.

Existing work in translation demonstrate the potential of massively multilingual machine translation by training a single model able to translate between any pair of languages. Researchers create a true Many-to-Many multilingual translation model that can translate directly between any pair of 100 languages. The researchers build and open-source a training

data set that covers thousands of language directions with parallel data, created through large-scale mining, further exploring how to effectively increase model capacity through a combination of dense scaling and language-specific sparse parameters to create high quality models. The research focus on non-English-Centric models that bring gains of more than 10 BLEU when directly translating between non-English directions while performing competitively to the best single systems from the Workshop on Machine Translation (WMT) (Clark, 2021).

Normalizing flows provide a general mechanism for defining expressive probability distributions, only requiring the specification of a (usually simple) base distribution and a series of bijective transformations. There has been much recent work on normalizing flows, ranging from improving their expressive power to expanding their application. We believe the field has now matured and is in need of a unified perspective. In this review, we attempt to provide such a perspective by describing flows through the lens of probabilistic modeling and inference. We place special emphasis on the fundamental principles of flow design, and discuss foundational topics such as expressive power and computational trade-offs (Papamakarios;Nalisnick;Rezende;Mohamed;& Lakshminarayanan, 2021).

Topological data analysis (TDA) uses tools from algebraic and combinatorial topology to extract features that capture the shape of data (Gunnar, 2009). The very active research field of TDA provides algorithms that can be used at any step of a ML pipeline. Giotto-tda application developed aims to make these algorithms available in a form that is useful to both the research and data science communities, thus allowing them to use TDA as a part of large-scale ML tasks. Despite its power and versatility, TDA has remained outside the toolbox of most machine learning (ML) practitioners, largely because current implementations are developed for research purposes and not in high-level languages. The aim of researchers to develop giotto-tda application is to fill the existing gap by making TDA accessible to the Python data science community, while supporting multidisciplinary research (Tauzin, ym., 2021).

Machine learning researchers have embraced the advances in mathematical programming allowing new types of models to be pursued. The special topic includes models using quadratic, linear, second-order cone, semidefinite, and semi-infinite programs. We observe that the qualities of good optimization algorithms from the machine learning and optimization perspectives can be quite different. Mathematical programming puts a premium on accuracy, speed, and robustness. Since generalization is the bottom line in machine learning and training is normally done off-line, accuracy and small speed improvements are of little concern in machine learning. Machine learning prefers simpler algorithms that work in reasonable computational time for specific classes of problems. Reducing machine learning problems to well-explored mathematical programming classes with robust general purpose optimization codes allows machine learning researchers to rapidly develop new techniques. In turn, machine learning presents new challenges to mathematical programming (Bennett & Parrado-Hernandez, 2006). Research in ML and research in MP have become increasingly coupled. ML researchers are making fuller use of the branches of the MP modeling tree.

Social scientists are now in an era of data abundance, and machine learning tools are increasingly used to extract meaning from data sets both massive and small. Researchers explain how the inclusion of machine learning in the social sciences requires us to rethink not only applications of machine learning methods but also best practices in the social sciences. In contrast to the traditional tasks for machine learning in computer science and statistics, when machine learning is applied to social scientific data, it is used to discover new concepts, measure the prevalence of those concepts, assess causal effects, and make predictions. The abundance

of data and resources facilitates the move away from a deductive social science to a more sequential, interactive, and ultimately inductive approach to inference. Scholars in recent times explain how an agnostic approach to machine learning methods focus on the social science tasks in order to facilitate progress across a wide range of questions and fields (Grimmer;Roberts;& Stewart, 2021).

Abundance now defines the social sciences. The rapid expansion of available data has shifted the evidence base. Election scholars used to rely on occasional surveys administered around national elections; now, researchers use voter files with millions of records. International relations scholars can bolster careful reading of archives with the analysis of millions of declassified state department cables. The difference is not just a matter of scale. New forms of data can fundamentally change our ability to measure phenomena; for example, tracking the removal of social media posts in real time provides a new window into how authoritarian regimes control information available to the public. Computing power has also exploded, with personal computers able to analyze millions of rows of data and more powerful cloud computing services readily available (Grimmer;Roberts;& Stewart, 2021).

Machine learning (ML) has become increasingly influential to human society, yet the primary advancements and applications of ML are driven by research in only a few computational disciplines. Even applications that affect or analyze human behaviors and social structures are often developed with limited input from experts outside of computational fields. Social scientists—experts trained to examine and explain the complexity of human behavior and interactions in the world—have considerable expertise to contribute to the development of ML applications for human-generated data, and their analytic practices could benefit from more human-centered ML methods. Many social science disciplines rely heavily on qualitative methods to distill patterns that are challenging to discover through quantitative data. One common analysis method for qualitative data is qualitative coding. The field of computational social science has emerged to support analysis of ever larger datasets. Nevertheless, progress in applying computational methods like ML to social science research has been relatively slow compared to fields like security, healthcare and ageing (CHEN, 2018).

Human migration is a type of human mobility, where a trip involves a person moving with the intention of changing their home location. Predicting human migration as accurately as possible is important in city planning applications, international migration, trade, spread of infectious diseases, conservation planning, and public policy development. Traditional human mobility models, such as gravity models or the more recent radiation model, predict human mobility flows based on population and distance features only. These models have been validated on commuting flows, a different type of human mobility, and are mainly used in modeling scenarios where large amounts of prior ground truth mobility data are not available. One downside of these models is that they have a fixed form and are therefore not able to capture more complicated migration dynamics. Researchers propose machine learning models that are able to incorporate any number of exogenous features, to predict origin/destination human migration flows. Machine learning models outperform traditional human mobility models on a variety of evaluation metrics, both in the task of predicting migrations between regions as well as international migrations. In general, predictive machine learning models of human migration will provide a flexible base with which to model human migration under different what-if conditions, such as potential sea level rise or population growth scenarios (Robinson & Dilkina, 2017).

Many sociologists start with a causal hypothesis and aim to investigate it, often using assumptions about how the data were generated. For instance, we might assume the data come

from a linear model. The generative assumptions are important—if they hold, then the model is meaningful in describing the causal relationship. In machine learning, the philosophy is usually very different. We might aim to predict an outcome with the only assumption being that the data are drawn independently from an unknown distribution. In that case, we would not assume a particular form for the model that generates the data, but we would try to predict on new data drawn from that distribution anyway. These big philosophical differences do not mean, however, that these two areas are incompatible—quite the contrary. But it does raise the question of how machine learning can help to address critical social science questions (Rudin, 2015).

3.0 Research Objective

This study seeks to underscore the need for an AI-driven integration program aka *Apptigration* in Finland in order to 1) accelerate integration program implementation for most disadvantaged immigrants in Finland; 2) change perception held on socio-cultural reception of the Finnish society by global South immigrants; and 3) improve awareness and access to relevant opportunities in the labour market.

The paper attempts to address two research questions;

1. What is the probability of accelerating integration by using Artificial Intelligence-led mobile App to co-facilitate integration of new immigrants into Finland?
2. To what extent is the AI-led integration holistic in supporting immigrants to integrate in Finland?

A holistic approach to integration will improve the sense of achievement and fulfillment among immigrants resulting in good mental health and well-being, dignified life and well-planned ageing in the high North. The current silo-driven integration approach will continue to result in negative perception among the immigrants resulting in a frustrating ageing or emigration to other favorable countries.

The challenges with using AI-driven *apptigration* includes the bias in the AI algorithms that may allocate low-tier opportunities to immigrants from the global south. In addition, low or now usage of the App can mean that the challenges remain the same. The perceptions and attitudes towards the App can also determine and influence the uptake and use of the App for facilitating integration by new and old immigrants.

4.0 Methodology

This applied research aims at solving the existing challenges linked to integration in Finland using predictive analytics algorithms. The researcher randomly selected social media discussions on integration topical issues from five most followed Facebook groups for immigrants in Finland between January and June 2021. Additionally, the researcher participated in three organized online forums via zoom and teams by associations of African immigrant communities in Finland, and took notes on the integration-related issues raised by participants and the suggested solutions.

The researcher uses mixed methods approach to analytically review high-quality peer-reviewed publications on AI and ML across disciplines, and using NVIVO, extrapolates linkages to integration. The researcher uses systematic reviews and meta-analyses combining results from multiple impact evaluation studies from various disciplines to make predictions and draw conclusions for the use of AI in accelerating and enhancing new migrants' settlement into the Finnish society. This mixed method approach ropes in quasi design approach and phenomenological approach to determine the qualitative and quantitative outputs and outcomes

of an algorithm-driven integration program impact on work, family, studies, refugee/ asylum seeker and other basis of immigration of Africans into Finland. The Africans are selected as the sample group of interest, as they are perceived to be among the most vulnerable and marginalized group in Finland. The study relies on secondary data to draw its conclusion on the potential impact of AI and ML on the integration of immigrants.

4.1 Quasi Design Approach

The researcher used a randomized approach to analyze print and social media feedback on topical issues around integration and challenges faced by immigrants in the labour market, education, aging and general welfare between January and June 2021. The review and analysis were based on social media engagements on integration-linked themes and were analyzed on random days during the period. The researcher used immigrant-driven social media groups with membership drawn from Sub Sahara African countries to ensure that the views collected were drawn from the global South, and in particular from Africa. Two hundred fourteen opinion pieces were analyzed and classified into the different taxonomies of work, education, family and refugees/ asylum seekers. MAXQDA was used to analyze and profile the opinions of the social media users. The opinions were analyzed and information used to extrapolate the outcome of the conventional integration program for different taxonomies.

4.1.1 Work-based Migration

Whereas majority of migration into Finland is based on work, it is not very common to find migrants from Africa to Finland on the basis of work. This is likely due to the lack of recognized qualifications from African institutions of higher learning by Finland. Bias was perceived where Africans that had used English language in their academic path had to take an English as a foreign language test whereas the Finnish nationals did not need to despite using Finnish language as a medium of facilitating learning throughout their education. There is a largely inferior perception of the African immigrants' capacity to handle professional work as compared to other immigrants from the north. There is no foreseeable (in the short and long run) intervention that can result in a solution to accelerate equal employment of Africans in the job market, except in specific fields such as ICT where racial microaggressions and intersectionality still creates impediments for Africans. Other regions from the world, especially the North-North migrants can benefit significantly from an accelerated integration for work-based immigrants. Achieving an accelerated integration program for work-based immigration is a win for this taxonomy that is never included in any form of integration into the Finnish society. This is a long-term benefit for future Africans that will migrate on the basis of work when the impediments to work-based migration is eliminated from the Finnish labour market.

4.1.2 Family-based Migration

A high number of Africans move to Finland for family reasons either as spouses to Finnish citizens, or as spouses to other nationalities including spouses to other Africans. In 2013, 33% of third-country nationals moved to Finland for family reasons. Family-based immigrants receive integration support through their municipalities. Immigrants have however expressed dissatisfaction on the quality and quantity of integration programs across Finland, especially as one moves north of Finland. The higher one settles in Finland, the more difficult their integration process becomes. The Finnish integration program focuses on teaching immigrants Finnish or Swedish language, and to facilitate the access to job markets with African immigrants channeled to the sectors perceived as odd jobs market. The integration program however offers support to ensure that one secures a source of income and livelihood regardless of the immigrants specialty. Family-based migration also receives some child support in the

form of babysitting for immigrants that participate in the integration programs, a benefit appreciated by the immigrants.

During the Covid-19, a self-paced integration program that is implemented remotely would have been impactful according to the new and existing immigrants that needed support. The suspension of in-person activities and events, and the suspension of crowding resulted in slowed or delayed integration of new immigrants that arrived into Finland from 2019 to 2021 and possibly, beyond. This was exacerbated by the government guidelines to limit movement at some stage, thus limiting the ability of the new immigrants to gather information from informal sources that could have bridged their lack of information. It is estimated that more than half of the immigrants that arrived in Finland in mid-to-late 2019 to 2021 have not received a comprehensive integration program and thus, they have a feeling of being left out or losing a sense of belonging. An immigrant shared that since her arrival into Finland, she had felt isolated, lonelier and more lost.

4.1.3 Studies-based Migration

Study-based migration is the second top basis for migration to Finland by third-country nationals after family reasons. In 2013, 28% of third-country nationals migrated for studies reason (StatisticsFinland, 2014). Until the autumn of 2017, education in Finland was free for all accepted students including African students (StudyEU, 2016). This made the study basis one of the easiest-to-explore avenues for migration by Africans with a mission to migrate to Finland. African immigrants have shown resilience in their ability to adapt to the Finnish society with an estimated eight in ten immigrants likely to stay on in Finland after completing their studies for work or other reasons. This estimate is anchored on the pareto principle. Africans forecast an easy transition when they get into the Finnish society and forecast economic integration into their preferred fields of studies. The reality is that when African immigrants get to Finland, they seldom find suitable career opportunities in their fields of study. Due to lack of economic opportunities in Africa, the immigrants choose to further their studies with the hope of unlocking the career prospects in Finland, where they can work and save before returning to Africa. But the cycle never ends as the job market takes time to penetrate, with very high expectations on immigrants to learn and use Finnish language. A paradox to this has been deconstructed by researchers that questioned why Finland was seeking talent from abroad while neglecting highly skilled labour already in the country (Khan, Maury, & Ndomo, 2021). They argued that the labour market in Finland is highly segmented, which means that migrants in general, but in particular from outside the EU, tend to find paid work in the low-paid service sector. Additionally, they noted that for the foreign population in Finland, the biggest challenge to recognition of skills and qualifications is neither limited to qualifications obtained abroad, nor documented skills on paper.

4.1.4 Refugees/ Asylum seekers

Finland refugee statistics for 2020 was 23,483, a 0.11% increase from 2019 (Macrotrends, 2021). The refugees/ asylum seekers air their frustrations through social media and mainstream media whenever interviewed. East and central Africa refugees get allocated some quotas annually. There seems to be a general lack of adequate information and support with well-packaged information targeting the refugees/ asylum seekers when they arrive at the reception centers in Finland. This is exacerbated by the perception of being held hostage at the reception centers. The situation is worse for refugees/ asylum seekers with vulnerable family members with special needs and disability as the staff at the reception centers do not have skills for supporting the special needs. The security apparatus and authorities also treat the refugees/ asylum seekers as potential criminals, with studies on insecurity centered around the refugees/

asylum seekers, especially from the Muslim countries. The refugees' human rights and liberties are violated when they are not adequately informed and provided with the right information when they are taken into the reception centers. Their vulnerability may also put them in a situation that they may not listen to understand at the very initial stages of being transferred to a reception center.

4.1.5 Benefits of Quasi design approach

The quasi design approach has been beneficial as the information is drawn from individuals that voluntarily air their views, opinions and reactions to various issues affecting their stay in Finland. The views, opinions and reactions do have rejoinders from other immigrants in or that know an immigrant in a similar situation. The discussions are illuminating as they are not regulated by political correctness, and allow the participants in a discourse to air their thoughts freely on various topical issues, and even share their experiences and suggested solutions in some of the cases. The researcher also has the liberty to engage in the discussion as another immigrant and seek clarities and responses to specific issues affecting the immigrants. The quasi design approach is accessible freely provided that one joins the membership groups and complies with the house rules of the group. This makes the quasi design affordable and convenient for getting preliminary thoughts and views about topical issues affecting various categories of immigrants. Quasi design paints a quick picture about the spoken words on the street.

4.2 Phenomenological Approach

This paper begins by analyzing the identified specific and continued forms of migration, and whether the forms conform to the traditional forms of mobility in the countries of origin in Africa (Baker & Aina, 1997). This paper further reviews whether migrants develop new forms of migration, and the differences that exist if any, from what prompted migration earlier. This paper further analyzes the observed behavioral changes in immigrant behaviors in Finland, different from that of their home countries in Africa. A predictive model is theoretically developed using the pareto principle to demonstrate the use of AI in accelerating integration and settlement into Finland in a more holistic fashion. The historical knowledge informs the challenges known along the timeseries, and suitable algorithms are coined to avert or offer solutions to pressing challenges faced by immigrants in different epochs.

4.2.1 Artificial Intelligence in Work and Family-based Migration

The use of AI can rapidly improve the living experience for African migrants that move to Finland based on work and family reasons. These are the two top reasons for migration to Finland according to the Finnish Immigration Service (2020), forming the taxonomy on the basis of work and family. AI has the capacity to accelerate the integration process for all immigrants especially African immigrants that migrate based on family and work using a self-paced and lifelong algorithm-driven program. The topological dynamics in the two taxonomies are enhanced by the tailored nature of the integration modules for accuracy of guidance and concreteness of information for accelerated integration in different situations that the immigrants fall in.

It is observed that a household with more than one immigrant will have different needs for their integration into the Finnish society compared to a household of a single person. It has also been reported by Finnish Immigration Service that majority of immigrants on the basis of work seldom participate in the integration program (Finnish Immigration Service, 2021). The systemic exclusion of immigrants on the basis of work from the integration program leaves them vulnerable to misinformation and lacking in awareness about useful information that may facilitate their holistic integration into the Finnish society. The extent to which an immigrant

needs integration services is critically determined by for instance, whether the immigrant moved to Finland alone or with other members of his or her household. The needs and intensity of integration services increases as household members increase, and as an immigrant continues to stay in Finland. The immigrants from the global South including Africa require more assistance due to their vulnerability to the socio-cultural, political, technological and climatic conditions of the high North.

Additionally, immigrant children learning in Finland encounter the use of second language in their education. Their guardians, often their parents struggle with the second language used as the official medium of communication by education authorities and other authorities in Finland (Ojwang, 2021). The use of AI can enhance and support holistic learning among children and adults in Finland. The law ensures that all immigrants and asylum seekers who live in Finland and are of compulsory education age (7–17 years) are entitled to the same basic education as Finns. In basic education, pupils of compulsory education age are placed on the grade level that matches their age, with perceived equitable capacity to gain knowledge and skills. In addition, remedial teaching in various subjects are provided for newcomers (Ministry of Education and Culture, 2021). The process of having the additional academic support approved and allocated is bureaucratic and laborious in some instances considering the amount of time it takes the teachers to diagnose, evaluate and assess the needs by a learner. A complimenting AI-driven platform can be engaged to accelerate catch-up by immigrant learners and other weaker students.

4.2.2 Artificial Intelligence in Studies-based Migration

Studies is the third top leading basis for migration into Finland according to the Finnish Immigration Services (2020), making the third taxonomy to be studies. Adult learners from Africa moving to Finland in pursuit of higher education experience new learning challenges besides other known and emerging challenges due to the coronavirus pandemic. Majority of immigrants from the global South to the high North where technology plays a central role in education and everyday way of life, play catch-up with digital component in learning and information-search, especially in the advent of the new normal. A complimenting AI-led self-paced learning approach has the potential to improve the integration process and accelerate student catch-up in using technology in learning and everyday life.

According to Miera (2012), the constant inflow of migrants to Finland creates new challenges and simultaneously awakens a lot of discussion and emotions. Most often discussions and emotions are connected to a lack of clarity of concepts and strong political connotations to them. The term ‘integration’ originally functioned as a theoretical concept. However, with time the concept became politicised. Nowadays most countries have some kind of integration policy and the term ‘integration’ functions as a theoretical as well as a political concept (Kärkkäinen, 2017).

In higher education, the immigrant adult learners can use AI to accelerate their self-paced integration and expand their knowledge and awareness about the Finnish society outside of the normal school and working hours. This is considering the average immigrant from the global South including Africa will require as a priority, to secure a job in order to earn some livelihood income. The self-paced AI-driven integration program for higher education learners or immigrants on the basis of studies can provide guidance on the use of library, public transport, university facilities, shopping for Africans by region e.g. East Africans, West Africans, Central and Southern Africans, house hunting and home insurance, and leisure amenities, among other utilities, and services to achieve a holistic integration. This ensures that the students get to optimize the university facilities available at their disposal and general

information applicable to their situation drawn from the typology for a more impactful learning experience and gratifying settlement in Finland.

4.2.3 Artificial Intelligence in Refugee/ Asylum seekers' migration

The AI can be used in offering a self-paced integration program and an introduction to the Finnish society's socio-cultural, political and technological awareness programs for a better understanding and appreciation of the Finnish society. Refugees/ Asylum seekers from protracted crisis contexts including in Central and Horn of Africa are vulnerable and feel marginalized in Finland in several sectors including in healthcare (Tuomisto;Tiittala;Keskimäki;& Helve, 2019), well-being (Hartonen;Väisänen;Karlsson;& Pöllänen, 2020), security (Palander, 2019), labour market (Ndomo & Lillie, 2020) and many other spheres. Using the translated version into the refugee/ asylum seekers' local languages, the Refugees/ asylum seekers can get useful information tailored to their context and situation. The topological algorithm ensures that the grievances raised by refugees/ asylum seekers in the reception centers and when they join the Finnish society are eliminated, or significantly reduced over a period. AI has the potential to accelerate the significant reduction and eventual elimination of the grievances as resourceful support are to be developed for each situation and challenge affecting refugees/ asylum seekers.

Refugees/ Asylum seekers have been linked to key issues affecting the Finnish society. A BBC article (2015) highlighted the integration challenges, crime, disinterest to learn Finnish, high cost of the reception centers and other reasons underscoring the perception of Finns towards the refugees/ asylum seekers. AI has the advantage of being able to handle the different refugees/ asylum seekers in their different situations and challenges specific to them. Migration challenges in Finland keep expanding from the originally identified impediments, as the policy does not resolve the challenges with finality. AI can illuminate what the nuances are that derail integration of refugees/ asylum seekers are, and resolve them meticulously and seamlessly without conflicts and human-engineered impediments. AI has the advantage of using the languages best understood by the refugees/ asylum seekers to ensure justice and equal dissemination of integration process.

4.2.4 Artificial Intelligence in Ageing

It is estimated that today, approximately 10 percent of the world's population is over the age of 60 and by 2050, this proportion will have more than doubled. Moreover, it is forecasted that the greatest rate of increase will be among the 'oldest old', people aged 85 and over (Pollack, 2005). The applications of modern Artificial Intelligence (AI) algorithms in aging and ageism research offer tremendous opportunities for increased quality of 'oldest old' quality of life. Aging is acknowledged as a universal unifying feature possessed by all living organisms, tissues, and cells. Latest technology-driven deep learning techniques used to develop age predictors offer new possibilities for previously incompatible dynamic and static data types. AI biomarkers of aging enable a holistic view of biological processes and allow for novel methods for building causal models—extracting the most important features and identifying biological targets and mechanisms. Modern technology-driven AI is therefore making significant contributions to the credibility and prominence of longevity biotechnology in the healthcare and pharmaceutical industry, and to the convergence of countless areas of research (Alex Zhavoronkov P. M.-K., 2019).

Most recent interventions have seen practical frameworks developed to guide nurse investigators integrating clinical data with sensor data for training machine learning algorithms may build capacity for nurses to make significant contributions to developing AI for health-assistive Smart Homes (Roschelle L. Fritz, 2019). The intersection of recent advances in AI and

aging research yields many new tools and applications for the pharmaceutical industry to exploit at every step of the research and development process as well as in personalization, marketing, and real-world evidence. Multimodal age predictors (predictors that integrate multiple data types) at the very minimum can provide deeper insights into biological data management. Not all data types are of equal biological importance and relevance. Age predictors are excellent tools for a broad range of experiments (Alex Zhavoronkov P. M., 2019).

Building on the knowledge gathered on the application of AI in aging research informs the argument on which this paper is constructed. The paper uses the same rationale and arguments used by the researchers on aging using AI to construct an argument for accelerating integration among immigrants.

4.2.5 Artificial Intelligence engineers holistic integration solution

AI offers the panacea to the life-long immigration challenges linked to integration in the migration trajectory. The simulation of human processes by machines delivers accurate and expeditious solutions to various challenges in the different taxonomies and topologies' combinations. By integrating machine learning, AI enables systems to learn patterns from existing data and subsequently improve future experience for new immigrants in an accelerated fashion. This is the most accessible, cost effective and accurate approach that has the potential to improve migration narratives and change the stories by immigrants from marginalized and minority areas.

4.3 Theoretical Framework

An analysis of two empirical AI-driven research articles on aging is used to make prediction patterns for migration trajectories among immigrants including African immigrants in Finland. The three articles are; 1) Deep aging clocks: The emergence of AI-based biomarkers of aging and longevity that focuses on longevity with the help of AI; 2) A nurse-driven method for developing AI in 'smart' homes for aging-in-place that complements what the healthcare homes provide. The first article focuses on longevity just as this paper focuses on accelerating integration process, while the second article focus on complimentary support for dignified aging just as thus paper focus on the use of an AI-driven App for complimenting integration services offered by the municipalities in Finland. This paper borrows on the two arguments to theoretically make predictions for achieving accelerated holistic integration in Finland.

The aging research provides useful techniques and findings for developing timeseries that can be used to model sequences and epochs for accelerating integration of immigrants by using Recurrent Neural Networks (RNN). Finding familiar food, meeting people from an immigrants' home country, ability to find guidance to everyday challenges and even navigate the job market accelerate the sense of one feeling integrated. This paper argues using grounded theory to help analyze various theories and concepts that explain the patterns generated by the algorithms in accelerating integration. The theories can help conceptualize plans for institutionalizing integration programs for immigrants coming to Finland and across the global North. The applications of modern AI algorithms in aging and ageism research offer tremendous opportunities for increased quality of 'oldest old' quality of life. This paper uses this concept to accelerate and improve the quality of integration among immigrants in Finland.

AI biomarkers of aging enable a holistic view of biological processes and allow for novel methods for building causal models—extracting the most important features and identifying biological targets and mechanisms (Alex Zhavoronkov P. M.-K., 2019). The use of AI in integration offers an accelerated self-paced life-long holistic integration in Finland. The

different epochs are algorithmically predicted along the cyclical timeseries and best solutions offered for immigrants using the Apps for integration.

Most recent interventions have seen practical frameworks developed to guide nurse investigators integrating clinical data with sensor data for training machine learning algorithms may build capacity for nurses to make significant contributions to developing AI for health-assistive Smart Homes (Roschelle L. Fritz, 2019). The concept is applied in complimenting the integration services offered by the municipalities, with the integration App acting as a complimenting platform and not a substitute. The App offers an expanded integration support beyond what the municipalities offer – job market preparation and learning the Finnish or Swedish language. In addition, the App comes with a multilingual feature making it unique and inclusive for non-English speakers, the most common language used for integration programs.

4.3.1 Recurrent Neuron Networks

The Recurrent Neuron Network (RNN) helps in modeling sequences using historical data. RNNs are networks with loops in them. They enable neurons to represent the history of observations in different epochs or timeseries. Their predictions are based on the hidden state (h_t) determined by the input (x_t) and relayed through the output (y_t).

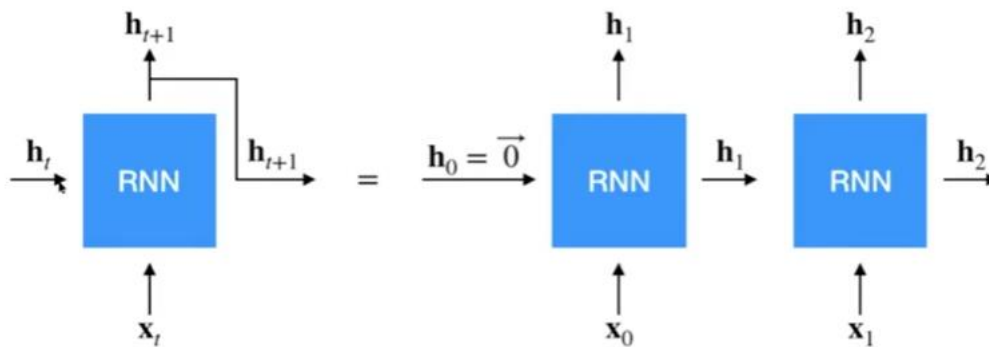
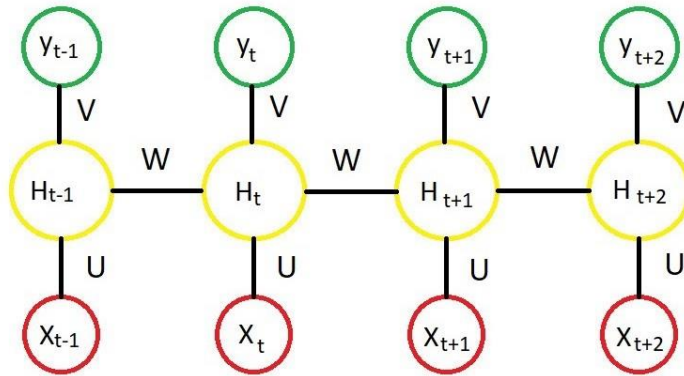

Figure 1. Recurrent Neuron Network illustrated

At each of the time points, the network gets input data. The data comprises the big data that helps in making accurate predictions and best choices when using the AI-driven App. The RNN modeling sequence formula bases on the history of the sequence to offer the best guidance to the immigrants using the App.



U = Weight vector for Hidden layer
V = Weight vector for Output layer
W = Same weight vector for different Timesteps
X = Word vector for Input word
y = Word vector for Output word

At Timestep (t)

$$H_t = \sigma (U * X_t + W * H_{t-1})$$

$$y_t = \text{Softmax} (V * H_t)$$

$$J^t(\theta) = - \sum_{j=1}^{|M|} y_{t,j} \log \bar{y}_{t,j}$$

$$J(\theta) = - \frac{1}{T} \sum_{t=1}^T \sum_{j=1}^{|M|} y_{t,j} \log \bar{y}_{t,j}$$

M = Decision (Guidance), J(θ) = Choice to make

Figure 2. Recurrent Neuron Network formula

4.3.2 Point forecast (training)

The point forecasting method takes the hidden state which is a vector encoding the history of the sequence up to a certain point, and output a single point forecast or the estimate of that point forecast. This is useful when offering guidance to immigrants that are seeking solutions or guidance that are typically sought at specific times during one's stay in Finland. The forecast is trained using mean squared error loss with respect to the ground truth for the next time point. This offers guidance to immigrants with the next challenge anticipated and adequately addressed.

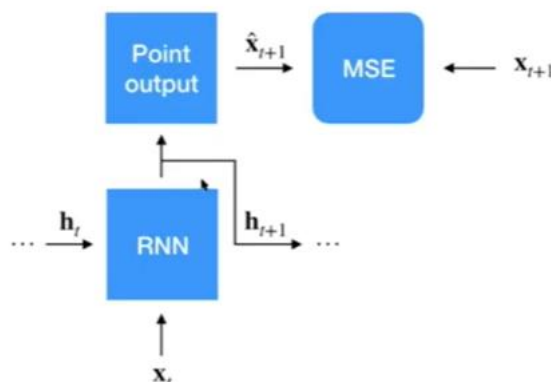

Figure 3. Point forecast (training) illustration

4.3.3 Point forecast (inference)

When the model is used for prediction, RNN is run over historical data to get warm up state given by hidden state (h_t). The state of this RNN is continued into prediction time by feeding

its predicted output back into the RNN together with the next state h_{t+1} . With RNNs, we can get a forecast for as many steps into the future as we desire, just by feeding the output back into the neural network. This can be helpful when making predictions in an immigrants integration process for example in the job market as they gain experience at work and earn more qualifications.

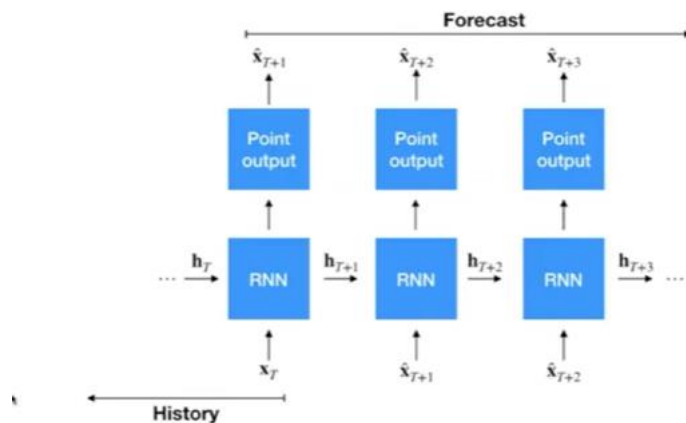

Figure 4. Point forecast (inference) illustration

4.3.4 Lag Features

Predictions are enhanced using the covariates that use timeseries built on additional useful information such as the taxonomy and topology-defining profiles. In addition, embeddings are used for categorical variables and allows for relationships between variables to be captured. The time features are central to the predictions. The use of time data helps to accelerate a sense of feeling integrated in the Finnish society in one way or another. The previous time values of a timeseries make an excellent prediction for the next turn point. This is due to the cyclic nature of many time series.

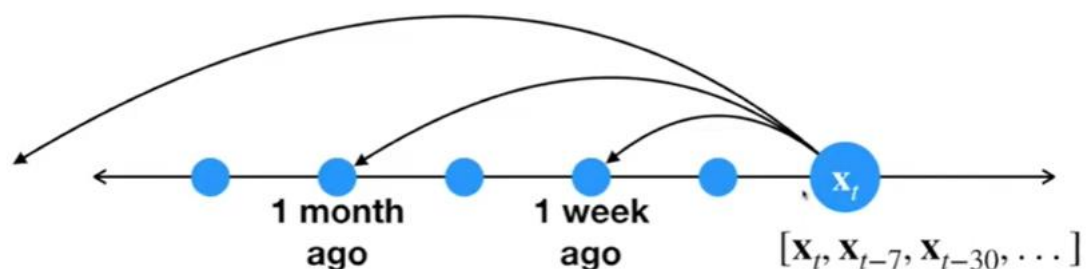

Figure 5. Lag Features

The problem of modeling uncertainties in timeseries forecasting is important for assessing how much to trust the prediction for downstream tests such as anomaly detection or decision making. Importance of the forecast in regions of low noise vs regions of high noise cannot be distinguished. This may make the algorithmic decisions bias in some cases.

5.0 Results and Discussion

The analysis of existing literature is very lean on AI-driven integration of immigrants in the global North including Finland. The existing literature and articles are in other disciplines like aging and medical sciences. The AI-driven interventions in aging have shown remarkable impact and potential to prolong the lives of human beings using a combination of simple remedies that are easy to access. There is little literary work on aging in Africa, and thus there was limited data to refer to on AI work in Africa around aging, but aging remains a universal unifying feature possessed by all living organisms, tissues, and cells regardless of demographic factors. The basing of this paper on AI-driven solutions for aging are adopted in arguing for integration of immigrants in Finland. Use of AI-driven solutions show arithmetically that the immigrants can get more help and attain a sense of being fast and better integrated into the Finnish society within their control. The use of a self-paced App transfers the integration control from the state authorities to the immigrants. This has the potential to improve the welfare state and mental health of immigrants at scale.

The aim of this paper is to demonstrate through predictive models that it is possible to accelerate integration into the Finnish society by about one-third the time used currently by immigrants to feel integrated into the Finnish society. With majority of immigrants including African immigrants having good access to smartphones and internet in Finland, AI-driven integration can aid in accelerating individualized and situation-specific information packages tailored for specific taxonomies and topologies to achieve an inclusive integration service provision that is equitable for different contexts or basis of migration. Traditionally, migrants on the basis of education and work miss out on integration as they arrive and join the work force.

This paper demonstrates the possibilities to build synergy between what is traditionally offered by the municipalities to immigrants as integration support, and compliment it with the AI-driven integration App. In addition, the AI-driven integration App leverages the AuroraAI program by the government of Finland that is targeting Finns, and expands the bracket of government awareness program to include immigrants. This bridges the time that would otherwise take longer to achieve in the absence of an AI-driven integration solution by almost one-fifth the time.

This paper acknowledges the possible biases, cyber security and related threats, potential under-usage by immigrants that may delay or affect the quality of integration information received by immigrants. The paper relies on research to understand the needs of the immigrants and builds the argument for the AI-driven integration solution on the basis of existing challenges that immigrants need solved urgently such as how to access employment opportunities, how to connect with other citizens from their home countries, where to find familiar foods in the municipality of residence and a general access to various categories of information that enhance settling in Finland.

Theories and Concepts

This paper uses grounded theory to validate the arguments presented by the author. The theories of inclusion and multiculturalism is prominent in the use of AI-driven solution for accelerating integration of immigrants as the theory attempts to make sense of the multicultural landscape and address demonstrated needs within their student populations. This paper demonstrates an individualized approach to eliminating or reducing the frustrations associated with lack of support in Finland. This *theory* includes the process of knowledge construction, integration of content, reduction of prejudice, empowering both social and school culture that

is all under sharp focus in the AI-driven integration solution. The theory of accelerating evolution posits that the only norm is accelerating change.

The Theory of Accelerating Evolution provides the basis for reconceptualizing the aging process, a key argument that has formed the basis for arguing for AI in accelerating integration. The theory acknowledges that human and environmental field rhythms are speeding up because of adoption of technology (Butcher, 2021). The Theory of Emergence of Paranormal Phenomena further suggests that experiences commonly labeled “paranormal” are actually manifestations of the changing diversity and innovation of field patterning or timeseries. They are pandimensional forms of awareness, examples of pandimensional reality that manifest visionary, beyond-waking potentials.

Karl Marx’s conflict theory comes to the forefront when seeking and finding accelerated solutions for immigrants that feel discriminated against and marginalized. **Conflict theory** looks at society as a competition for limited resources. Social institutions like government, education, and religion reflect this competition in their inherent inequalities and help maintain the unequal social structure. Poorly executed integration programs or lack of it creates a potential derailment in the society by the immigrants, especially the most disadvantaged and vulnerable ones (Marx, 1973). An AI-driven integration App with the capacity and ability to accelerate integration can reduce inequality and the feeling or perception of social injustice among immigrants. The theory of race and ethnicity is a constant mention where social injustice exists, especially among the people of colour like Africans. The functionalism concept argues in part that dysfunctions associated with racism include the failure to take advantage of talent in the subjugated group, and that society must divert from other purposes the time and effort needed to maintain artificially constructed racial boundaries (Arnold, 1951). The integration program and process in Finland does not in any way, contribute to equitable access to opportunities and resources. The use of an AI-led may expand the opportunities bracket by linking the right opportunities with the matching qualification held by an immigrant. Where as the systemic challenges in the hiring process may continue, the immigrants will be able to pursue the right opportunities and this may be the starting point for driving an agenda for equity in the professional disciplines for which the immigrants hold the required qualifications.

Most researchers and observers do agree that technology at least an exponential rate. Some theorists have expressed their thoughts that it is increasing at a hyperbolic rate, meaning that it will suddenly jump to infinite advancement (Spacey, 2016). The exponential vs hyperbolic concept is demonstrated in the predictable nature of the AI-driven integration, and in its long-life nature to offer suggested solutions and guidance using big data accumulated over time as immigrants use the technology in different epochs. Exponential and hyperbolic growth are often confused as they both feature steady increase in growth or decline. This paper illuminates a case of steady increase in support to immigrants with more accurate information over time.

6.0 Conclusion

This is the first step in conceptualizing and rolling out the Aptigration in Finland. The predictive model shows that the integration of technology by using an AI-driven App can accelerate the sense of feeling integrated among immigrants. This feeling and perception that is associated with it plays a key role in the mental health and wellbeing of immigrants. The data can quantitatively generate information to provide links between specific patterns and

integration patterns that are situation-specific for a gratifying migration story among immigrants. The predictive models have demonstrated that:

- Use of AI can provide an accelerated approach to help achieve **holistic integration** of immigrants in one-third of the time, in multiple languages
- Use of AI can help majority of the immigrants to access **tailored integration services** for their basis of migration
- Use of AI can help the immigrants that are traditionally excluded from integration to be included (migrants on other basis outside family and refugee basis)
- Use of AI can provide a **self-paced, life-long** guidance in Finland
- Use of AI **compliments** the municipality programs (language and job market)

The scope of the AI-led integration is holistic and goes further beyond the traditional two-thronged scope of integration offered by the municipalities that focus on first, learning the Finnish language, and second, accessing the labour market. The AI-led integration focus is in all facets of the society including food and the markets, clothing and shopping, entertainment and lifestyle, news and weather, indigenous people and way of life in Finland, Finnish tradition and norms among other reasons. The AI-led integration is a perfect compliment to the existing two-thronged integration offered by the municipalities.

References

- [1] Alex Zhavoronkov, P. M. (2019). Deep Aging Clocks: The Emergence of AI-Based Biomarkers of Aging and Longevity. *CellPress Reviews*, 546-549.
- [2] Alex Zhavoronkov, P. M.-K. (2019). Artificial intelligence for aging and longevity research: Recent advances and perspectives. *Aging Research Reviews*, 49-66.
- [3] Arnold, R. (1951). *The roots of prejudice*. Retrieved from UNESCO: <http://unesdoc.unesco.org/images/0007/000733/073342eo.pdf>.
- [4] Baker, J., & Aina, T. (1997). *The Migration Experience in Africa*. Uppsala: GOTAB.
- [5] BBC. (2015, Sep 9). *Europe Migrant crisis*. Retrieved from BBC: <https://www.bbc.com/news/world-europe-34185297>
- [6] beam, A. L., & Kohane, I. S. (2018). Big Data and Machine Learning in Health Care. *JAMA Network*, 1317-1318.
- [7] Bennett, K. P., & Parrado-Hernandez, E. (2006). The Interplay of Optimization and Machine Learning Research. *Journal of Machine Learning Research*, 1265–1281.
- [8] Butcher, H. K. (2021). Concepts Developed within the Science of Unitary Human Beings. In H. K. Butcher, *Martha E. Rogers' Nursing Science*. Iowa: Iowa Press.
- [9] CHEN, N.-C. (2018). Using Machine Learning to Support Qualitative Coding in Social Science: Shifting The Focus to Ambiguity. *ACM Transactions on Interactive Intelligent Systems*, 39.1-39.21.
- [10] Clark, A. (2021). Beyond English-Centric Multilingual Machine Translation. *Journal of Machine Learning Research*, 1-48.
- [11] Finnish Immigration Service. (2021, Jan 20). *Statistics on immigration 2020*. Retrieved from Finnish Immigration Service: <https://migri.fi/en/-/statistics-on-immigration-2020-most-immigrants-come-to-finland-to-work-the-coronavirus-affected-the-number-of-applications>
- [12] Grimmer, J., Roberts, M. E., & Stewart, B. M. (2021). Machine Learning for. *Annual Review of Political Science*, 395-419.
- [13] Gunnar, C. (2009). Topology and data. *Bull. Amer. Math. Soc*, 255-308.

- [14] Hartonen, V. R., Väisänen, P., Karlsson, L., & Pöllänen, S. (2020). 'Between heaven and hell': Subjective well-being of asylum seekers. *International Journal of Social Welfare*, 30-45.
- [15] Jahnukainen, M. (2021, February 09). *About transit research*. Retrieved from University of Helsinki: <https://blogs.helsinki.fi/transit-okl/tietoa/transit-tutkimus-nuorten-koulutuspoluista-peruskoulun-jalkeen/about-transit-research/>
- [16] Kärkkäinen, K. (2017). *Learning, teaching and integration of adult migrants in Finland*. Jyväskylä: University of Jyväskylä.
- [17] Khan, J., Maury, O., & Ndomo, Q. (2021, Jun 30). *Labour market*. Retrieved from RASTER.FI: <https://raster.fi/2021/06/30/why-does-finland-look-for-talent-from-abroad-but-neglect-highly-skilled-foreigners-in-the-country/>
- [18] Liu, M., Xia, Y., Cho, K., & Cai, T. (2021). Integrative High Dimensional Multiple Testing with. *Journal of Machine Learning Research*, 1-26.
- [19] Macrotrends. (2021, Oct 04). *Refugee Statistics*. Retrieved from Macrotrends: <https://www.macrotrends.net/countries/FIN/finland/refugee-statistics>
- [20] Manhaeve, R., Dumančić, S., Kimmig, A., Demeester, T., & Raedt, L. (2021). Neural probabilistic logic programming in DeepProbLog. *Elsevier*.
- [21] Marx, K. (1973). *The heritage of sociology*. Chicago: University of Chicago.
- [22] Meira, F. (2012). Not a one-way road? Integration as a concept and as a policy. *Edinburgh University Press*, 192-212.
- [23] Miller, T. (2019). Explanation in artificial intelligence: Insights from the social sciences. *Elsevier*, 1-38.
- [24] Ministry of Education and Culture. (2021, February 08). *Basic education for immigrants*. Retrieved from Study Info.fi: <https://studyinfo.fi/wp2/en/valintojen-tuki/education-for-immigrants/basic-education-for-immigrants/>
- [25] Ndomo, Q., & Lillie, N. (2020, Sep 28). *Experiences of Finnish Migrants and Refugees Show a Need for Stronger Measures against Job Market Discrimination*. Retrieved from SIRIUS Project: <https://www.sirius-project.eu/news/experiences-finnish-migrants-and-refugees-show-need-stronger-measures-against-job-market>
- [26] Ojwang, F. (2021). Social injustice in learning of the second language among immigrant children in Finland: conventional narratives and perceptions. *EUREKA: Social and Humanities*, 82-100.
- [27] Palander, J. (2019, Dec). *Mobility and the Security Paradigm: How Immigration Became Securitized in Finnish Law and Policy*. Retrieved from UEF//eRepository: <https://erepo.uef.fi/bitstream/handle/123456789/7639/15608554772066247449.pdf?sequence=2&isAllowed=y>
- [28] Papamakarios, G., Nalisnick, E., Rezende, D., Mohamed, S., & Lakshminarayanan, B. (2021). Normalizing Flows for Probabilistic Modeling and Inference. *Journal of Machine Learning Research*, 1-64.
- [29] PMI. (2022, Mar 14). *Megatrends*. Retrieved from PMI: <https://www.pmi.org/learning/thought-leadership/megatrends>
- [30] Pollack, M. E. (2005, 6 15). Intelligent Technology for an Aging Population: The Use of AI to Assist Elders with Cognitive Impairment. *AI Magazine*, p. 26(2).
- [31] PWC. (2022, Mar 14). *Megatrends*. Retrieved from PWC: <https://www.pwc.co.uk/issues/megatrends.html>

- [32] Robinson, C., & Dilkina, B. (2017, Nov 15). *A Machine Learning Approach to Modeling Human Migration*. Retrieved from Scilit: <https://www.scilit.net/article/f7f9448d0dc0ca70453aeb3d4a31b50b>
- [33] Roschelle L. Fritz, G. D. (2019). A nurse-driven method for developing artificial intelligence in “smart” homes for aging-in-place. *Nursing Outlook*, 140-153.
- [34] Rudin, C. (2015, Sep 21). *Essays - Can Machine Learning Be Useful for Social Science?* Retrieved from The cities papers: <http://citiespapers.ssrc.org/can-machine-learning-be-useful-for-social-science/>
- [35] Sambira, J. (2013, May). *Africa's mobile youth drive change*. Retrieved from Africa Renewal: <https://www.un.org/africarenewal/magazine/may-2013/africa%E2%80%99s-mobile-youth-drive-change>
- [36] Spacey, J. (2016, May 21). *Exponential-vs-hyperbolic*. Retrieved from Simplicable: <https://simplicable.com/new/exponential-vs-hyperbolic>
- [37] Statista. (2021, Aug 12). *Demographics*. Retrieved from Statista: <https://www.statista.com/statistics/274511/life-expectancy-in-africa/>
- [38] Statistics Finland. (2017, May 23). *Average life expectancy at birth was 78.5 years for boys and 84.1*. Retrieved from Statistics Finland: <http://www.stat.fi/til/kuol/2015/01>
- [39] StatisticsFinland. (2014, Oct 04). *Statistics Finland*. Retrieved from Statistics Finland: https://www.stat.fi/tup/maahanmuutto/uth-tutkimus_en.html
- [40] StudyEU. (2016, Jun 23). *SEG study abroad*. Retrieved from StudyEU: <https://studyeu.org/news/no-more-free-tuition-to-study-in-finland-from-autumn-2017/>
- [41] Tauzin, G., Lupo, U., Tunstall, L., Perez, J., Caorsi, M., Medina-Mardones, A., . . . Hess, K. (2021). giotto-tda: A Topological Data Analysis Toolkit. *Journal of Machine Learning Research*, 1-21.
- [42] Tuomisto, K., Tiittala, P., Keskimäki, I., & Helve, O. (2019). Refugee crisis in Finland: Challenges to safeguarding the right to health for asylum seekers. *Elsevier*.
- [43] Vinuesa, R., Azizpour, H., Leite, I., Balaam, M., Dignum, V., Domisch, S., . . . Nerini, F. F. (2020). The role of artificial intelligence in achieving the Sustainable Development Goals. *Nature Communications*.
- [44] West, D., & Allen, J. (2018). *How artificial intelligence is transforming the world*. Washington, DC: The Brookings Institution.
- [45] Yle News. (2016, January 18). *News*. Retrieved from Yle News: https://yle.fi/uutiset/osasto/news/finlands_teachers_concentrating_immigrants_in_the_same_areas_creates_problems/8602698

Statement of conflict of interest

On behalf of all authors, the corresponding author states that there is no conflict of interest.

Data availability statement

1. The detailed datasets generated during and/or analysed during the current study are stored in a google drive that is password protected and available upon reasonable request
2. The datasets generated during and/or analysed during the current study are available from the corresponding author on reasonable request and through the references.
3. The datasets generated during and/or analysed during the current study are publicly available and have been provided in the reference section of the article.