



vol. 17 / 2023



The 7th International Conference on Science Technology

organized by
Faculty of Social Science and
Law Universitas Negeri Manado and
Consortium of International Conference
on Science and Technology

The Innovation Breakthrough in Digital and Disruptive Era

Development of Adaptive Bandwidth Allocation Model Using PCQ for Network Performance Optimization

Salkin Lutfi¹, Syarifuddin Kapita², Hairil Kurniadi Sirajuddin³, Yasir Muin^{4*}

^{1,2,3,4} Informatic Department, Faculty of Engineering, Khairun University

Abstract. The number of clients has an impact on network performance, and while more bandwidth capacity can sometimes result in better network services, it is not always a given. Clients acquire the appropriate bandwidth, which is managed at the network layer by software, to control the flow and number of packets in the network. The practice of managing bandwidth includes measuring and controlling communications (traffic and packets) through network channels. This is done to prevent overburdening or overloading networks, which will lead to network congestion and poor performance. The goal of this study is to improve the internet network through bandwidth allocation using the PCQ approach. When it comes to sharing bandwidth with active users and large users, the results of the suggested strategy are excellent.

Keywords: *Management Bandwidth, Optimization, PCQ Method.*

* Corresponding author: yasirmuin@unkhair.ac.id

1 Introduction

The increasing internet requirements necessitate efficient bandwidth management[1]. A user or organization utilizing more bandwidth than they require will interfere with other users, which is just one of the many issues that unregulated internet bandwidth will bring about[2]. Limiting internet usage is one method of managing internet bandwidth to prevent one or more groups of internet users from monopolizing the entire available bandwidth[3]. Static bandwidth management, which has a straightforward configuration, is the approach that is frequently used to manage bandwidth. Static bandwidth sharing, however, may stop working well or become insufficient. Users who want less bandwidth waste it, whereas users who need more bandwidth are left unsatisfied[4].

The client receives all of the given bandwidth under static bandwidth management. The client bandwidth allotment cannot be changed[5]. Dynamic bandwidth management, on the other hand, allows for the adjustment of bandwidth allotment by keeping track of traffic and setting up network rules to handle client data flow. With the growing user base, the percentage of data services from internet applications keeps growing linearly. Congestion will develop in a network without effective management and control[6]. There are dynamic bandwidth management methods in Router OS. They are per-connection queues (PCQ). When there are no priority customers in the network, the PCQ approach is used. It sets up a network with the same bandwidth allocation. For various types of data flow, it can be utilized to implement diversified bandwidth management. PCQ only functions at the level of children.

Router OS created the PCQ bandwidth management method, a non-priority class queueing type that has the ability to limit bandwidth. The data-rate cap for each sub-queue is determined by the PCQ package limit (pcq limit) and PCQ rate (pcq rate). The PCQ queue's overall size must be less than the PCQ package's overall size limit. Download bandwidth balancing is achieved by setting the pcq-rate to 0 with the dst-address (outgoing interface) classification. The active client's upload bandwidth will be managed equally by the src-address classification option[7].

In networks with changing client counts, the PCQ approach is useful and effective. Each active client receives a bandwidth allocation that is distributed fairly evenly based on the number of active clients. J. Fair queueing (FQ), which distributes balanced packet streams, was first proposed by Nagle. The complex flow separation and data packet queue structures were required by the system since they needed separate queues for each data stream. Time-based scheduling algorithms and queue-based scheduling algorithms are two different categories of scheduling algorithms[8].

This research suggests the PCQ method for optimizing even bandwidth allocation. This model is designed to address the challenges of allocating bandwidth on a network in a user-dense campus environment, especially on a network that serves multiple connections at once.

2 Method

To control the quantity and flow of packets within a network, bandwidth management, a software-based congestion control strategy, is used. The PCQ approach is suggested in this article as a way to improve balanced bandwidth allocation. This approach is created to solve the difficulties of assigning bandwidth to networks in a campus environment with a high user density, particularly on networks that service many connections at once.

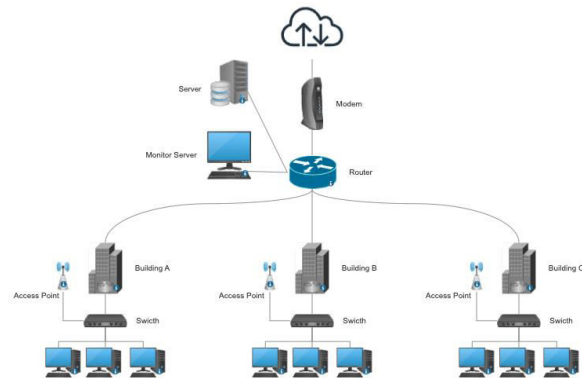

Fig. 1. The Network Topology.

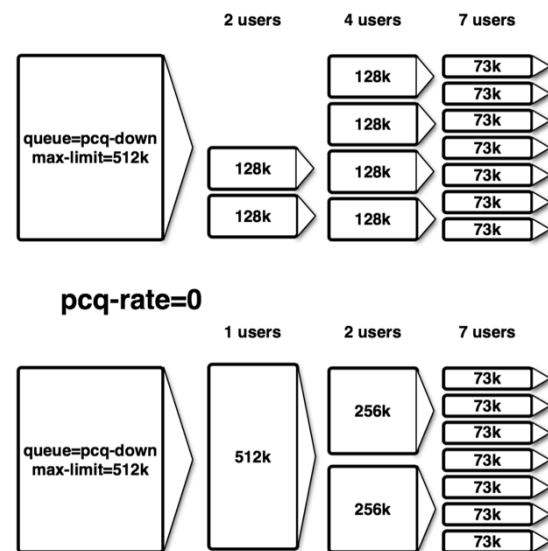

Fig. 2. The PCQ scheme.

A bandwidth-sharing method is used in the PCQ testing scheme shown in Figure 2 to distribute the available bandwidth across numerous active customers. Each client will receive 1:50 of the network's total bandwidth under this plan.

2.1 Packet Loss

Packet loss refers to a situation where one or more sent data packets do not arrive at their intended location. Following the formula below, the value of packet loss is determined.:

$$\text{Packet loss} = \frac{\text{Packet sent} - \text{Packet Receive}}{\text{Packet Sent}} \times 100 \quad (1)$$

Table 1. Network packet loss requirement.

Category	Packet Loss (%)	Indicator
Perfect	0	4
Good	3	3
Medium	15	2
Low	25	1

2.2 Delay/Latency

The amount of time required for data to travel from the sender to the recipient is known as latency. The following calculation can be used to determine the network's average delay.

$$\text{Average delay} = \frac{\text{Total dela}}{\text{Total packet receive.}} \quad (2)$$

Table 2. Network delay

Category	Delay (Ms)	Indicator
Perfect	<100	4
Good	100 - 350	3
Medium	350 - 500	2
Low	> 500	1

2.3 Jitter

The size of the version being delayed or the difference in the timing of the package's delivery are both examples of jitter. To determine the regular jitter on a network, apply the following formula.

$$\text{average Jitter} = \frac{\text{Total delay variation}}{\text{Total packet received}} \quad (3)$$

Table 3. Network jitter requirement

Category	Jitter (Ms)	Indicator
Perfect	0	4
Good	0- 75	3
Medium	75- 125	2
Low	125 - 255	1

3 Research Result

3.1 PCQ Data Rate

The simulation used up to ten repetitions at random. Figure 6 displays the outcomes of the PCQ method's average data rate addition to the NAC (number of active customers). First, the simulation uses a single client on the network that utilizes the entire amount of network capacity. Additionally, In the presence of other users, the average data rate is shared equally among all logged-in users. The bandwidth used by each active client depends on the total number of active clients.

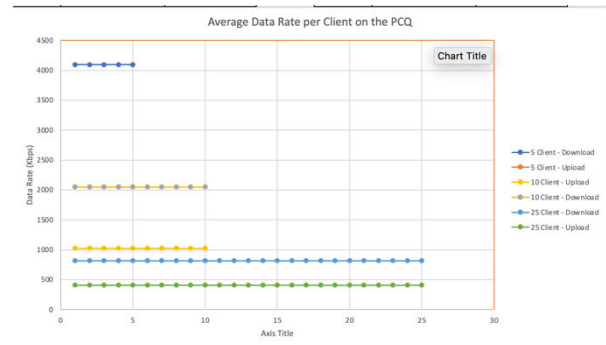

Fig 3. The PCQ Method's data rate for total active clients.

The capacity of PCQ to evenly share bandwidth with each client is demonstrated by the increase in average data rate that results from an increase in the number of clients. where the allocated bandwidth will be divided into two groups: lecturers and students. This PCQ method is very appropriate to be applied to networks that have a large number of users. Clients with a small number will get more bandwidth evenly from the maximum amount of bandwidth.

3.2 Quality of Services

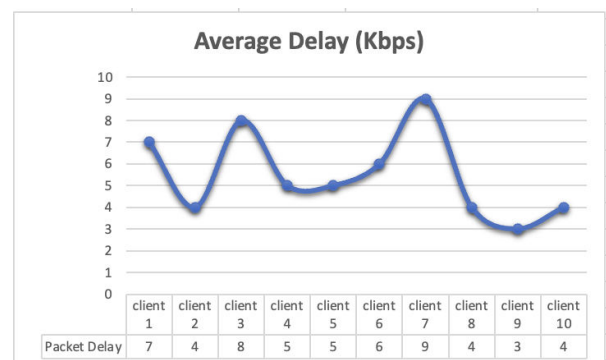

Fig 4. PCQ delay packet.

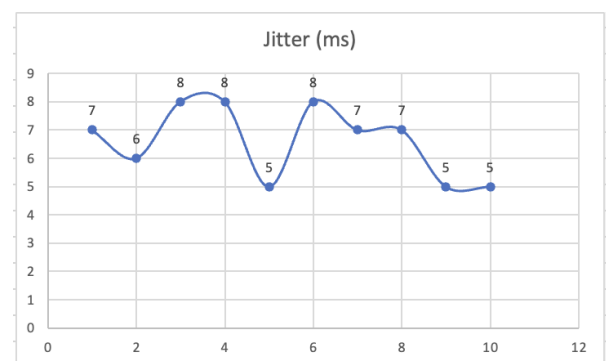

Fig 5. PCQ Jitter

Figure 4 shows the test results of the PCQ method, getting the average delay at index value 4 (the best category) for the presentation delay for each client of 150 Ms. While figure 5 shows that PCQ achieves an average jitter of 8 Ms for each client with a presentation index value of 3 (good category).

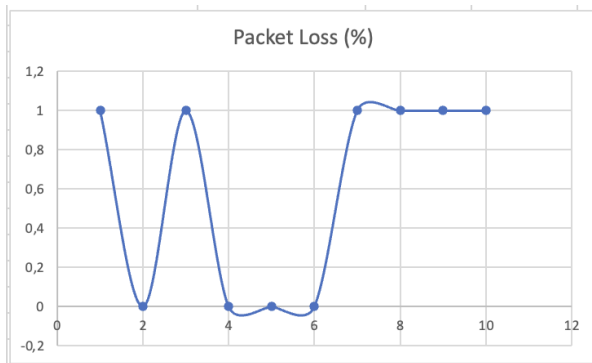

Fig 6. PCQ packet loss.

The packet loss presentation shown in Figure 6 is at an index value of 3 (good category), a condition that shows lost packets can occur due to collisions and congestion on the net. So that each client will experience a spike in packet loss if these problems occur.

Conclusion

The application of the PCQ method is the best alternative in bandwidth management to optimize the network. This algorithm is very suitable for being applied to networks with a large and dynamic number of users. The results of a bandwidth management implementation can provide bandwidth evenly to each client who gets an internet connection.

References

1. I. A. NWEKE, "The Good, the Bad and the Ugly of Tillage in Agricultural Sustainability– A Review," *Greener Journal of Agricultural Sciences*, vol. 8, no. 9, pp. 217–250, Sep. 2018, doi: 10.15580/GJAS.2018.9.090618130.
2. M. Mufadhol, G. Aryotejo, and A. Wibowo, "Netscan and networx for management bandwidth and traffic with simple routing," *Telkomnika (Telecommunication Computing Electronics and Control)*, vol. 15, no. 1, pp. 464–470, Mar. 2017, doi: 10.12928/TELKOMNIKA.v15i1.4183.
3. G. Aryotejo and M. Mufadhol, "Static and dynamic alliance: The solution of reliable internet bandwidth management," in *Journal of Physics: Conference Series*, Institute of Physics Publishing, Jun. 2019. doi: 10.1088/1742-6596/1217/1/012126.
4. J. Elias, F. Martignon, A. Capone, and G. Pujolle, "A new approach to dynamic bandwidth allocation in Quality-of-Service networks: Performance and bounds," *Computer Networks*, vol. 51, no. 10, pp. 2833–2853, Jul. 2007, doi: 10.1016/j.comnet.2006.12.003.
5. C. Braun and D. Petr, "Performance Evaluation of Dynamic and Static," Jun. 2003.
6. "INTERNET SOCIETY GLOBAL INTERNET REPORT 2015 MOBILE EVOLUTION AND DEVELOPMENT OF THE INTERNET."
7. "MikroTik RouterOS™ v3.0 Reference Manual."
8. G. Hong, J. Martin, and J. Westall, "Adaptive bandwidth binning for bandwidth management," *Computer Networks*, vol. 150, pp. 150–169, Feb. 2019, doi: 10.1016/j.comnet.2018.12.019.